

STRAUB-OPEN-FLEX 2 | ø 172.0 - 2032.0 mm

Components / Materials	W1	W2	W4	W5
Casing	S355MC, hot-dip galvanised	AISI 316 L or similar		AISI 316 L or similar
Bolts	AISI 4135	AISI 4135		A4 - 80
Bars	AISI 12L14, galvanised	AISI 12L14, galvanised		AISI 316 L or similar
Strip insert (option)	AISI 316 L or similar / HDPE	AISI 316 L or similar / HDPE		AISI 316 L or similar / HDPE
Sealing sleeve EPDM	Temp.: -20°C up to +100°C Medium: all qualities of water, waste water, air, solids and chemical products			
Sealing sleeve NBR	Temp.: -20°C up to +80°C Medium: water, gas, oil, fuel and other hydrocarbons			
Sealing sleeve FPM/FKM	Temp.: -20°C up to +180°C Medium: ozone, oxygen, acids, gas, oil and fuel (only with strip insert)			

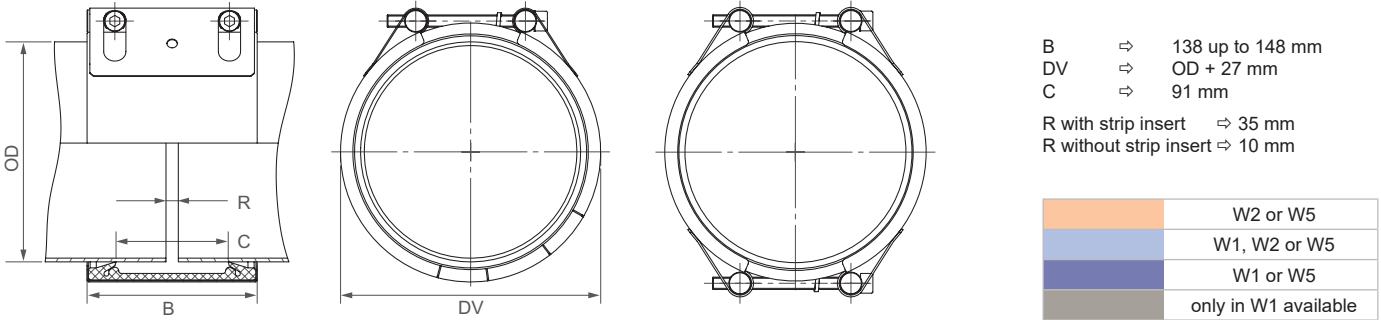

OD [mm]	Clamping range [mm]	PN						PN [bar]
		2.5	6	10	16	20	25	
172.0	169 - 175							Pressure rates according to type approval
180.0	177 - 183							
200.0	197 - 203							
219.1	216 - 223							
250.0	247 - 254							
267.0	263 - 272							
273.0	269 - 278							
304.0	300 - 309							
323.9	320 - 329							
355.6	352 - 360							
406.4	403 - 410							
457.2	453 - 462							
508.0	504 - 513							
558.8	555 - 564							
609.6	604 - 615							
711.2	707 - 717							
762.0	756 - 768							
812.8	807 - 819							
914.4	908 - 920							
1016.0	1010 - 1022							
1117.6	1112 - 1124							
1219.2	1213 - 1226							
1320.8	1314 - 1328							
1422.4	1416 - 1429							
1524.0	1517 - 1532							
1600.0	1593 - 1608							
1625.6	1619 - 1634							
1727.2	1720 - 1735							
1828.8	1822 - 1837							
1930.4	1923 - 1938							
2032.0	2025 - 2040							

CONTINUOUSLY VARIABLE INTERMEDIATE SIZES FROM 172.0 TO 2032.0 mm ARE AVAILABLE

Remarks:

- Follow fitting instructions
- PN (🏭) = working pressure considering the application loads
Test pressure = PN (🏭) x 1.5 (e.g. industry, water supply etc.)
PN (🚢) = nominal pressure, includes four times safety factor (e.g. shipbuilding)
- Strip inserts are optional accessories (see Technical Manual STRAUB)
- Additional sealing sleeves, pressure and temperature ranges on request
- Clamping range of 1-part OPEN-FLEX are identical to FLEX

Versions:

PN						1 piece (slotted) [mm]	2 piece casing [mm]
2.5	6	10	16	20	25		
x	x					≤ 1219.1	on order
x	x					> 1219.1	on order
		x				172.0-355.6	on order
		x				355.6-457.2	on order
		x				457.2-711.2	on order
		x				> 711.2	on order
			x			≤ 219.1	on order
			x			219.1-1524.0	on order
				x		172.0-1016.0	on order
					x	180.0-762.0	on order

